

LSP-LRS-0310F-04

Laser Range Finder Module

# Technical Specification



*Lumispot*

## 1. Overview

LSP-LRS-0310F-04 laser range finder module is a laser range finder module developed based on the 1535nm erbium laser independently developed by *Lumispot* it adopts single pulse TOF ranging mode and has a maximum measuring range of >3km. It is composed of laser, transmitting optical system, receiving optical system and control circuit board, and communicates with host computer through TTL/RS422 serial port provides host computer test software and communication protocol, which is convenient for users to develop the second time. It has the characteristics of small size, light weight, stable performance, high impact resistance, first-class eye safety, etc., and can be applied to hand-held, vehicle-mounted, pod and other photoelectric equipment.

## 2. Structural Composition and Main Performance Indicators

The LSP-LRS-0310F-04 laser rangefinder consists of a laser, a transmitting optical system, a receiving optical system and a control circuit. The main performance is as follows:

### 2.1 Ranging Capacity

Visibility under the conditions of visibility is not less than 12km, humidity  $\leq$  80%:

- For large targets (buildings) ranging distance  $\geq$ 5km;
- For vehicles (2.3m $\times$ 2.3m target, diffuse reflectance  $\geq$ 0.3) ranging distance  $\geq$ 3km;
- For personnel (1.75m $\times$ 0.5m target plate target, diffuse reflectance  $\geq$ 0.3) ranging distance  $\geq$ 2km;
- For UAV (0.2m $\times$ 0.3m target, diffuse reflectance  $\geq$ 0.3) ranging distance  $\geq$ 1km.

### 2.2 Main functions

a) single ranging and continuous ranging;

- b) Multitarget ranging
- c) Self-test function.

### 2.3 Performance

- a. Wavelength: 1535nm±5nm;
- b. Laser divergence Angle:  $\leq 0.6\text{mrad}$ ;
- c. Continuous ranging frequency: 1~10Hz adjustable;
- d. Ranging accuracy:  $\leq \pm 1\text{m}$ ;
- e. Accuracy:  $\geq 98\%$ ;
- f. Minimum measuring range:  $\leq 15\text{m}$ ;
- g. Ranging resolution:  $\leq 30\text{m}$ ;
- h. Power supply voltage: DC5V ~ 28V;
- i. Weight:  $< 33\text{g} \pm 1\text{g}$ ;
- j. Power consumption: standby power consumption  $\leq 0.15\text{W}$ , average power consumption  $\leq 0.7\text{W}$  (1Hz), peak power consumption  $\leq 3\text{W}$ ;
- k. Size:  $\leq 48\text{mm} \times 21\text{mm} \times 31\text{mm}$ ;

### 2.4 Environment Adaptability

- a. Operating temperature:  $-40^{\circ}\text{C} \sim +60^{\circ}\text{C}$ ;
- b. Storage temperature:  $-55^{\circ}\text{C} \sim +70^{\circ}\text{C}$ ;
- c. Impact: 75g@11ms;
- d. Vibration: Vibration environment of combined wheel vehicles.

### 2.5 Interface

Communication interface: RS422, 115200bps

Electrical interface: The interface model is A1002WR-S-8P, and the interface definition is detailed in the following table.

Wire No	Definition	Remarks
1	VIN+	Power supply +
2	VIN-	Power supply -

3	RS422 TX+	RS422 Transmit +
4	RS422 TX-	RS422 Transmit -
5	RS422 RX-	RS422 Receive -
6	RS422 RX+	RS422 Receive +
		Module power supply enabled, TTL_3.3V level;
7	POWER_EN	Module on (> 2.7V or suspended) Module off (< 0.3V)
8	GND	Communication earthing

## 2.6 Mounting drawing

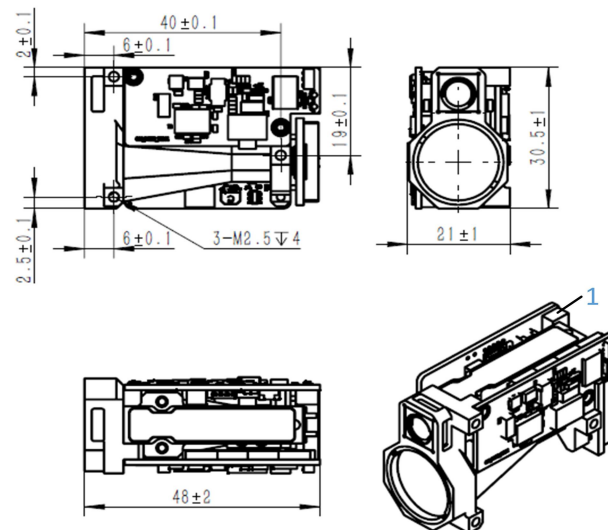

## 3. User Precautions

- The laser emitted by this rangefinder is  $1535 \pm 1$  nm, which is safe for human eyes. Although it is an eye-safe wavelength, it is advised not to look directly into the laser.
- When adjusting the parallelism of the optical axis, be sure to cover the receiving lens to avoid permanent damage to the detector due to excessively strong echoes.
- This rangefinder module is not airtight. Ensure that the relative humidity of the environment is below 80% and maintain a clean and sanitary

environment to prevent damage to the laser.

- The range of the rangefinder is related to atmospheric visibility and the nature of the target. Range will be reduced in fog, rain, and sandstorms. Targets like green tree clusters, white walls, and exposed limestone have better reflectivity and can increase range. Additionally, increasing the angle of the laser beam to the target will reduce the range.
- Do not emit lasers at highly reflective targets such as glass or white walls within 15 meters to avoid echo overstrength and damage to the APD detector.
- Do not plug or unplug cables while the device is powered on.
- Ensure the correct polarity of the power supply connection to avoid permanent damage to the equipment.