

LSP-LRS-0610F

Laser Range Finder Module

Technical Specification

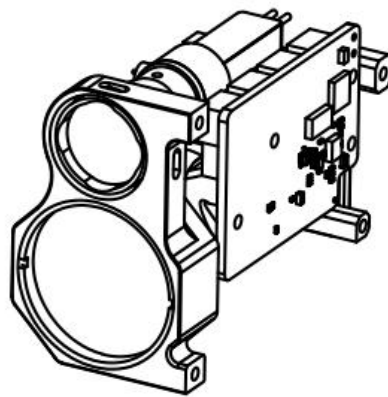

Lumispot

1. Overview

The LSP-LRS-0610F laser rangefinder module is a laser ranging module developed based on our company's independently researched and developed 1535nm Erbium laser. It adopts a single-pulse Time-of-Flight (TOF) ranging method with a maximum ranging distance of ≥ 6 km. Composed of a laser, transmitting optical system, receiving optical system, and control circuit board, it communicates with the host computer through RS422 serial port. It provides host computer test software and communication protocols, facilitating user secondary development. It boasts features such as small size, light weight, stable performance, high shock resistance, and Class 1 eye safety.

2. Structural Composition and Main Performance Indicators

The LSP-LRS-0610F laser rangefinder consists of a laser, a transmitting optical system, a receiving optical system and a control circuit. The main performance is as follows:

2.1 Ranging Capacity

Visibility under the conditions of visibility is not less than 20km, humidity $\leq 80\%$, the distance of large targets (buildings) ≥ 8 km; For vehicles (2.3m \times 2.3m target, diffuse reflectance ≥ 0.3) ranging distance ≥ 6 km; For personnel (1.75m \times 0.5m target plate target, diffuse reflectance ≥ 0.3) ranging distance ≥ 3 km.

2.2 Main functions

- a) single ranging and continuous ranging;
- b) Range strobe, front and rear target indication;
- c) Self-test function.

2.3 Performance

- a. Wavelength: 1535nm±5nm;
- b. Laser divergence Angle: ≤ 0.3mrad;
- c. Continuous ranging frequency: 1~10Hz adjustable;
- d. Ranging accuracy: ≤±1m;
- e. Accuracy: ≥98%;
- f. Minimum measuring range: ≤30m;
- g. Ranging resolution: ≤30m;
- h. Power supply voltage: DC5V ~ 28V;
- i. Weight: < 75g;
- j. Power consumption: standby power consumption ≤120mW, average power consumption ≤3W, peak power consumption ≤7W;
- k. Size: ≤65mm×48mm×32mm;

2.4 Environment Adaptability

- a. Operating temperature: -40°C ~ +60°C;
- b. Storage temperature: -55°C ~ +70°C;
- c. Impact: 75g@11ms;
- d. Vibration: Vibration environment of combined wheel vehicles.

2.5 Interface

Communication interface : RS422, 115200bps

Electrical interface: The interface model is A1002WR-S-10P, and the interface definition is detailed in the following table.

Wire No	Definition	Remarks
1	VIN+	Power supply +
2	VIN-	Power supply -
3	POWER_EN	Module power supply enabled, TTL_3.3V level; Module on (> 2.7V or suspended)

		Module off (< 0.3V)
4	RS422 TX+	RS422 Receive +
5	RS422 TX-(UART_TXD)	RS422 Receive- (UART Serial Send, TTL 3.3V Level)
6	RS422 RX-(UART_RXD)	RS422 Transmit- (UART Serial Receive, TTL 3.3V Level)
7	RS422 RX+	RS422 Transmit +
8	Reserved	
9	Reserved	
10	GND	Communication earthing

2.5 Mounting drawing

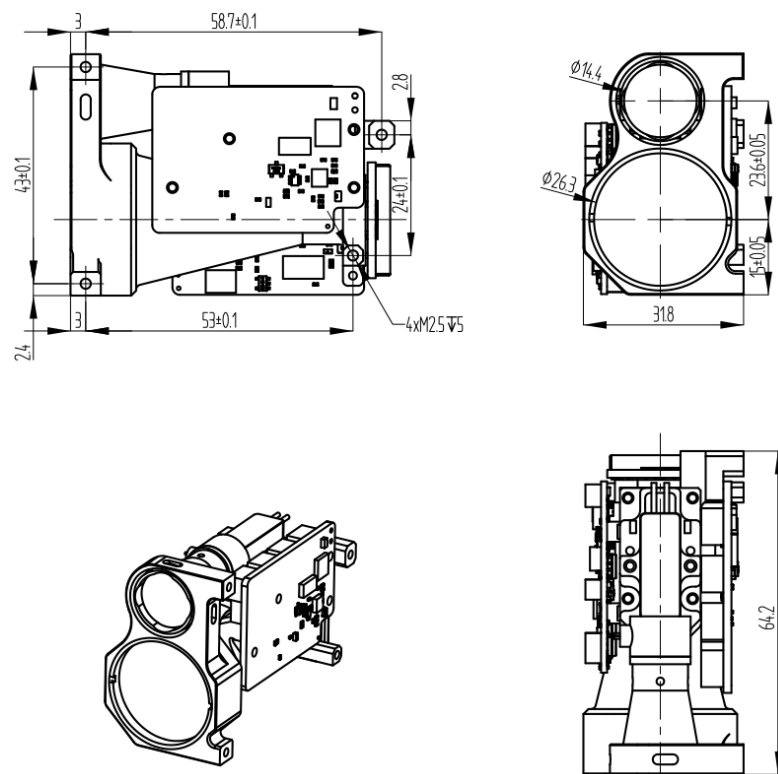

3. User Precautions

- The laser emitted by this rangefinder is 1535nm, which is safe for human eyes. Although it is an eye-safe wavelength, it is advised not to look directly into the laser.

- When adjusting the parallelism of the optical axis, be sure to cover the receiving lens to avoid permanent damage to the detector due to excessively strong echoes.
- This rangefinder module is not airtight. Ensure that the relative humidity of the environment is below 80% and maintain a clean and sanitary environment to prevent damage to the laser.
- The range of the rangefinder is related to atmospheric visibility and the nature of the target. Range will be reduced in fog, rain, and sandstorms. Targets like green tree clusters, white walls, and exposed limestone have better reflectivity and can increase range. Additionally, increasing the angle of the laser beam to the target will reduce the range.
- Do not emit lasers at highly reflective targets such as glass or white walls within 30 meters to avoid echo overstrength and damage to the APD detector.
- Do not plug or unplug cables while the device is powered on.
- Ensure the correct polarity of the power supply connection to avoid permanent damage to the equipment.